

LEGEND		
W	CLEAR OPENING WIDTH	
H	CLEAR OPENING HEIGHT	
X	WALL THICKNESS	
B	SPACE REQUIRED	
C	RETURN SPACE	
RO	ROUGH OPENING WIDTH	
ROH	ROUGH OPENING HEIGHT	

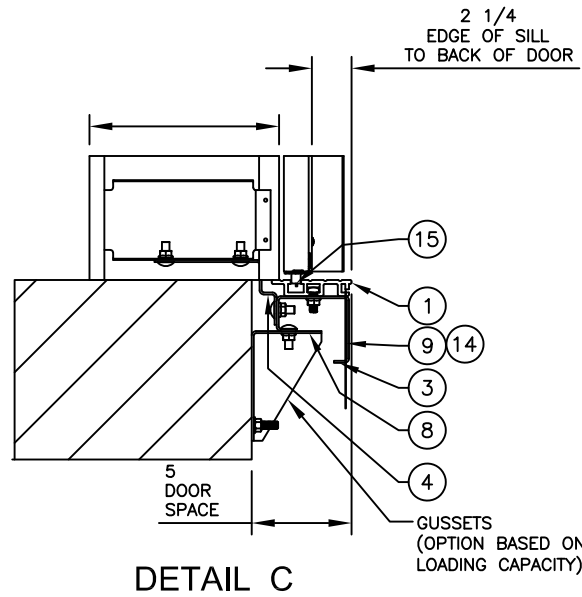
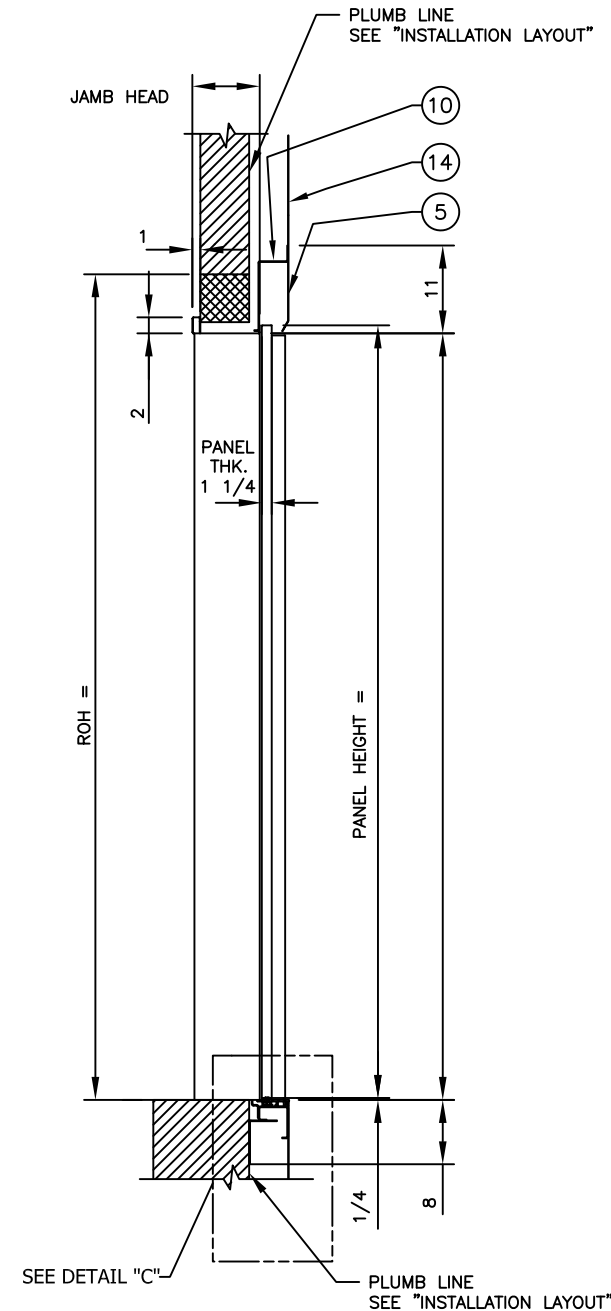
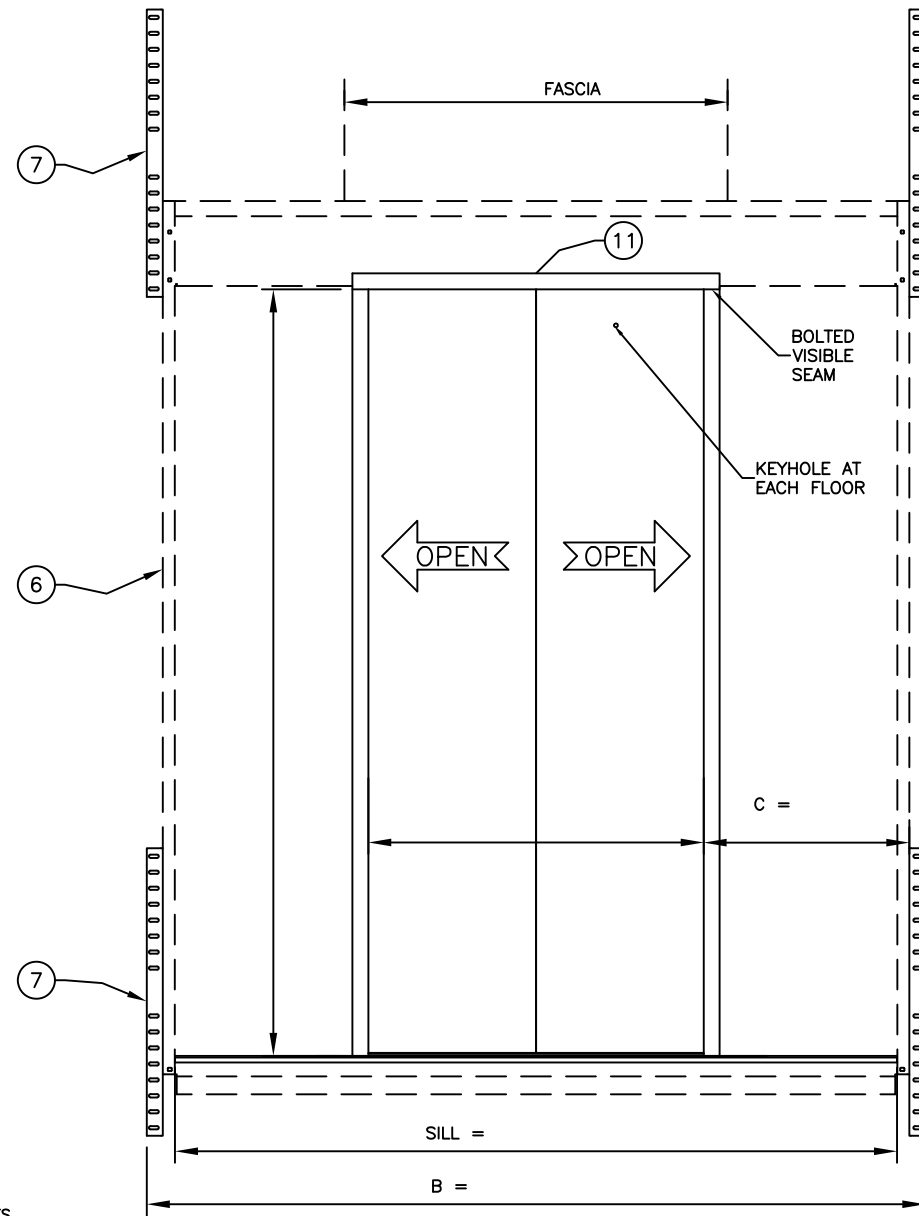
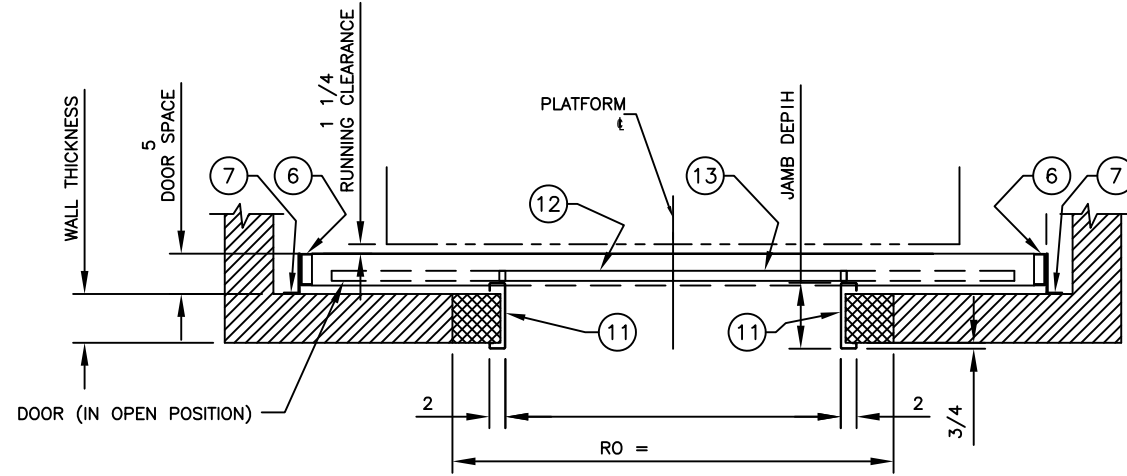

- NOTES
1. FRAME CAN BE USED FOR DRYWALL OR MASONRY WALL.
  2. ENTRANCE FRAMES ARE NOT DESIGNED TO SUPPORT OVERHEAD WALL LOADS.
  3. SUITABLE SUPPORT FOR THESE LOADS MUST BE PROVIDED BY OTHERS.
  4. ENTRANCES ARE UL LABELED. 1 1/2 HOUR (MINIMUM) RATING.
  5. ENTRANCES ARE PRE-DRILLED FOR GAL EQUIPMENT.
  6. IT IS RECOMMENDED THAT THE ENTRANCE WALL BE LEFT OPEN UNTIL DOOR FRAMES AND SILLS ARE SET IN PLACE IF THIS IS NOT POSSIBLE THEN A ROUGH OPENING MUST BE PROVIDED THAT IS 2'-0" WIDER AND 6" HIGHER THAN DOOR OPENING. WALL IS TO BE COMPLETED AND SILLS AND FRAMES AS REQUIRED ARE TO BE GROUTED BY OTHERS AFTER ENTRANCES ARE INSTALLED IN PLACE.

[ALL DIMENSIONS IN INCHES]  
DRAWING NOT TO SCALE

ITEM	BILL OF MATERIALS	MATERIAL	FINISH	QTY
1	SILL EXTRUDED	See Estimate		1
2	STRUT KNEE (NOT SHOWN)	12GA	GALV	4
3	SILL SUPPORT	12GA	GALV	1
4	JAMB BRACKET	12GA	GALV	2
5	HANGER COVER	16GA	GALV	1
6	STRUT	12GA	GALV	2
7	TIE ANGLE	12GA	GALV	4
8	GROUT RETAINER	12GA	GALV	1
9	TOE GUARD	16GA	GALV	1
10	HEADER_PSD	12GA	GALV	1
11	FRAME	See Estimate		1
12	DOOR ASSEMBLY	See Estimate		1
13	DOOR ASSEMBLY	See Estimate		1
14	FASCIA STARTER	16GA	GALV	1
15	DOOR GIBS	-		1
16	DUST COVER (NOT SHOWN)	16GA	GALV	1

**HARDWARE INSTALLATION KIT**

17A	PSD DOOR PANEL HARDWARE (INCLUDING GIBS & RETAINERS)	560028	-	2
17B	PSD ENTRANCE HARDWARE CO	560027	-	1
17C	SIGHT GUARD HARDWARE	560025	-	2
17D	FASCIA HARDWARE	560026	-	1
17E	PSD ANCHOR HARDWARE	560023	-	1
17F	DOOR ASTRAGAL	560018	-	2

**FOR APPROVAL**

**MATERIAL & FINISH**

DOOR FACE FINISH	See Estimate
DOOR BACK FINISH	See Estimate
FRAME FINISH	See Estimate
SILL MATERIAL	See Estimate

**QUANTITY BREAKDOWN**

QTY - See Estimate	1CO - W x H
--------------------	-------------



TITLE  
PSD ENTRANCE 1CO

BUILDING		APPROVED BY:	
LOCATION			
ELEV. NO:		DATE:	
SHEET 1 OF 1		JOB #:	